

Digital instrument cluster
VIC
Laplace Z

specification

version alpha

1

General description

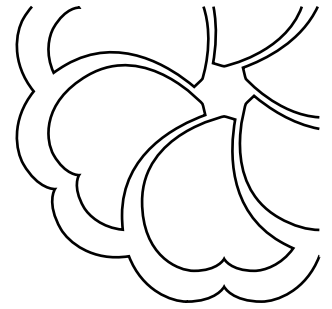

VIC Laplace Z is a rugged automotive digital instrument cluster. This high-performance embedded graphics processor features high-brightness wide display, avionic aluminum housing and aerospace interface connector.

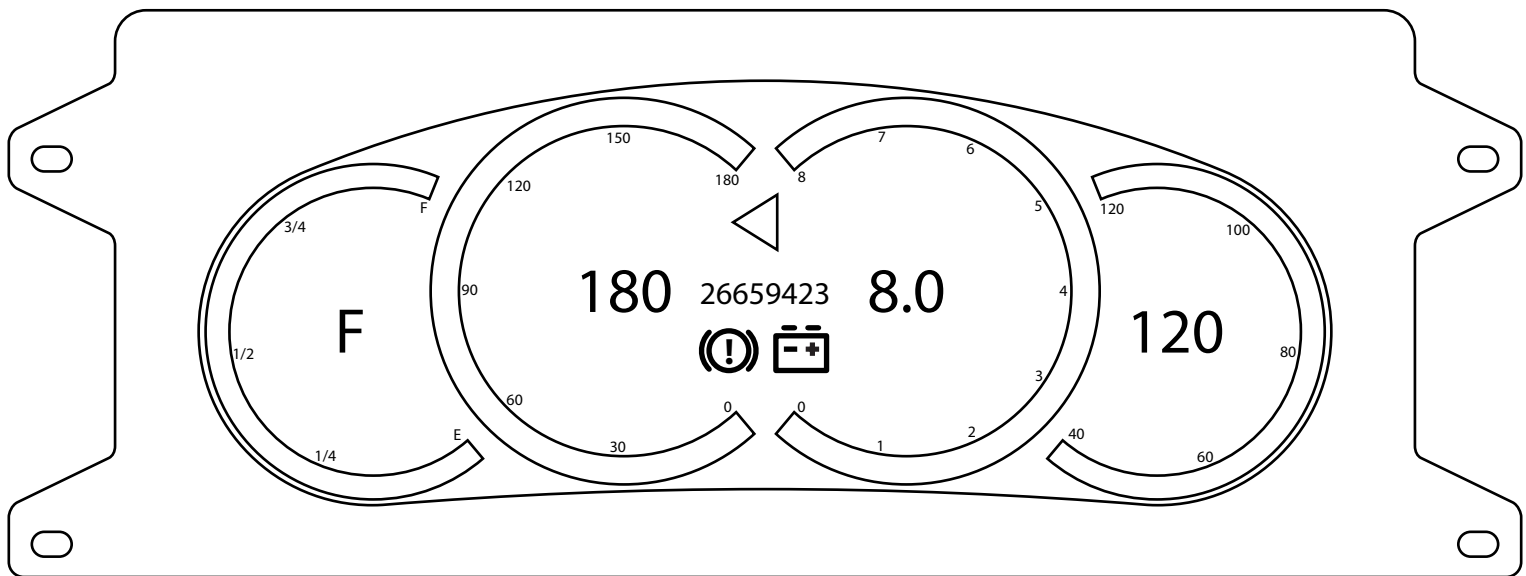

Fig. 1. VIC Laplace Z.

Cluster hardware is optimized for ultimate graphics performance and instant startup time.

As result the cluster has 60 *Hz* both display refresh rate and graphics frame rate — that is the display shows 60 frames per second and every frame is freshly built by graphics engine.

The cluster loads graphics and starts up in a fraction of a second.

2

Display

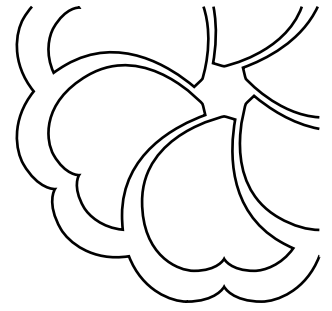

VIC Laplace Z is equipped with a rugged, high-brightness and high-contrast display of 1280×480 resolution and 8:3 aspect ratio.

Display data

view area size	293.76 <i>mm</i> ×110.16 <i>mm</i>
resolution	1280×480
aspect ratio	8:3
color resolution	18 <i>bit</i>
brightness	1000 <i>cd/m²</i>
contrast ratio	800
refresh rate	60 <i>Hz</i>
operating temperature	-30°C–80°C

Table 1. VIC Laplace Z display data.

The display diagonal is 314 *mm* or 12.5".

3

Hardware

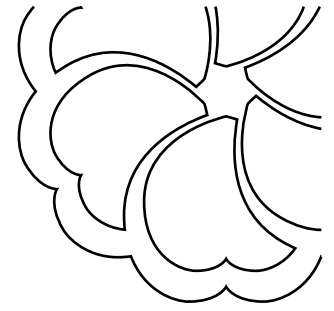

At its core VIC Laplace Z has Arm architecture plus 2D and 3D graphics engines capable of 60 *fps* frame rate for mixed scenes.

Hardware data

core frequency	400 <i>MHz</i>
graphics engine	2D and 3D
frame rate	60 <i>Hz</i>
flash memory	64 <i>MB</i>
DDR memory	128 <i>MB</i>
MRAM memory	256 <i>kB</i>
operating temperature	-40°C–85°C

Table 2. VIC Laplace Z hardware data.

The cluster has on-board three types of memory:

flash — for storing the graphics and code in off state

DDR — dynamic memory for graphics processing

MRAM — magnetoresistive memory for storing temporary data

Like *flash*, *MRAM* can store data in off state. But unlike *flash*, *MRAM* has unlimited resource of rewrite cycles, which makes it a perfect choice for frequently saved data storage like odometer, trip counter and settings.

4 Connector

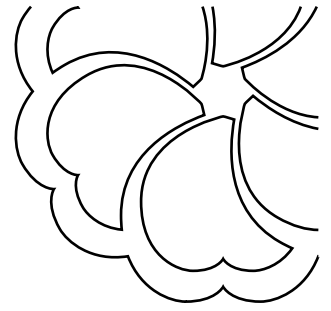

VIC Laplace Z has the only aerospace subminiature connector of *Tri-Start* series. The connector features high-performance gold plated pins.

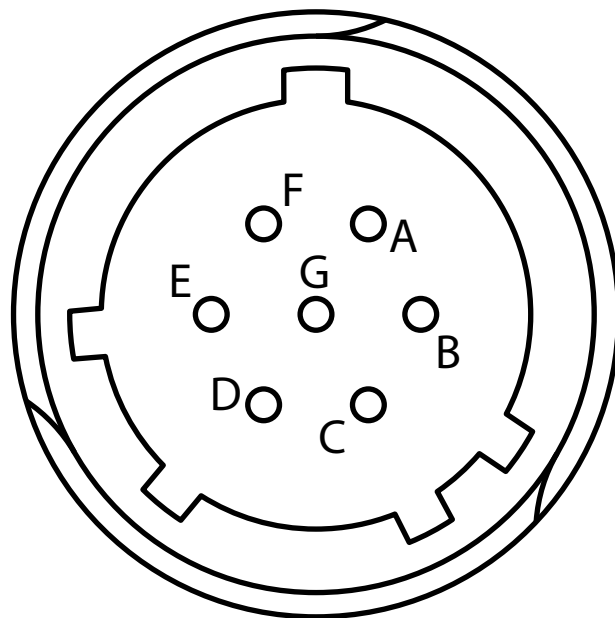
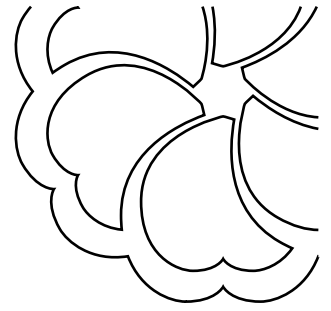

Fig. 2. VIC Laplace Z connector.

The mating plug is *D38999/26Z-B99SN*.

5

Interface



VIC Laplace Z has a digital interface — two *CAN* buses and an *Enable* line.

Pinout	
A	CAN2-
B	CAN2+
C	Enable
D	Power +12 V
E	CAN1+
F	CAN1-
G	Power -12 V

Table 3. VIC Laplace Z pinout.

The bus *CAN1* usually is used as the main data bus — for instance, standard *J1939*. The bus *CAN2* usually is programmed as custom control bus for instrument cluster control — brightness adjusting, mode switching and trip counter resetting. The buses are capable of up to 1 *Mb/s* transfer rate.

The *Enable* input is used for the instrument cluster startup and shutdown and could be connected to the ignition line of the vehicle. Its operating range is 4 V–80 V.

6

Electrical data

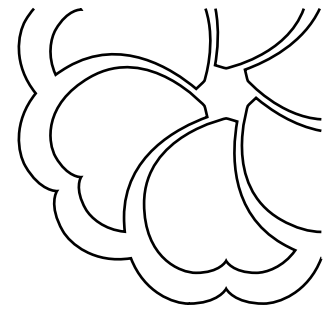

Digital instrument cluster VIC Laplace Z is designed to be used in 12 V systems and features the highest level of protection. Due to robust power stage it could be used in 24 V systems with corresponding precautions.

Electrical data

nominal power	12 V
operating range	6 V–80 V
reverse battery protection	<i>yes</i>
double battery protection	<i>yes</i>
power transient protection	IV level of <i>ISO 7673-2</i>
power dump protection	IV level of <i>ISO 16750-2</i>

Table 4. VIC Laplace Z electrical data.

As extra VIC Laplace Z features soft startup and gracious shutdown.

7

Dimensions

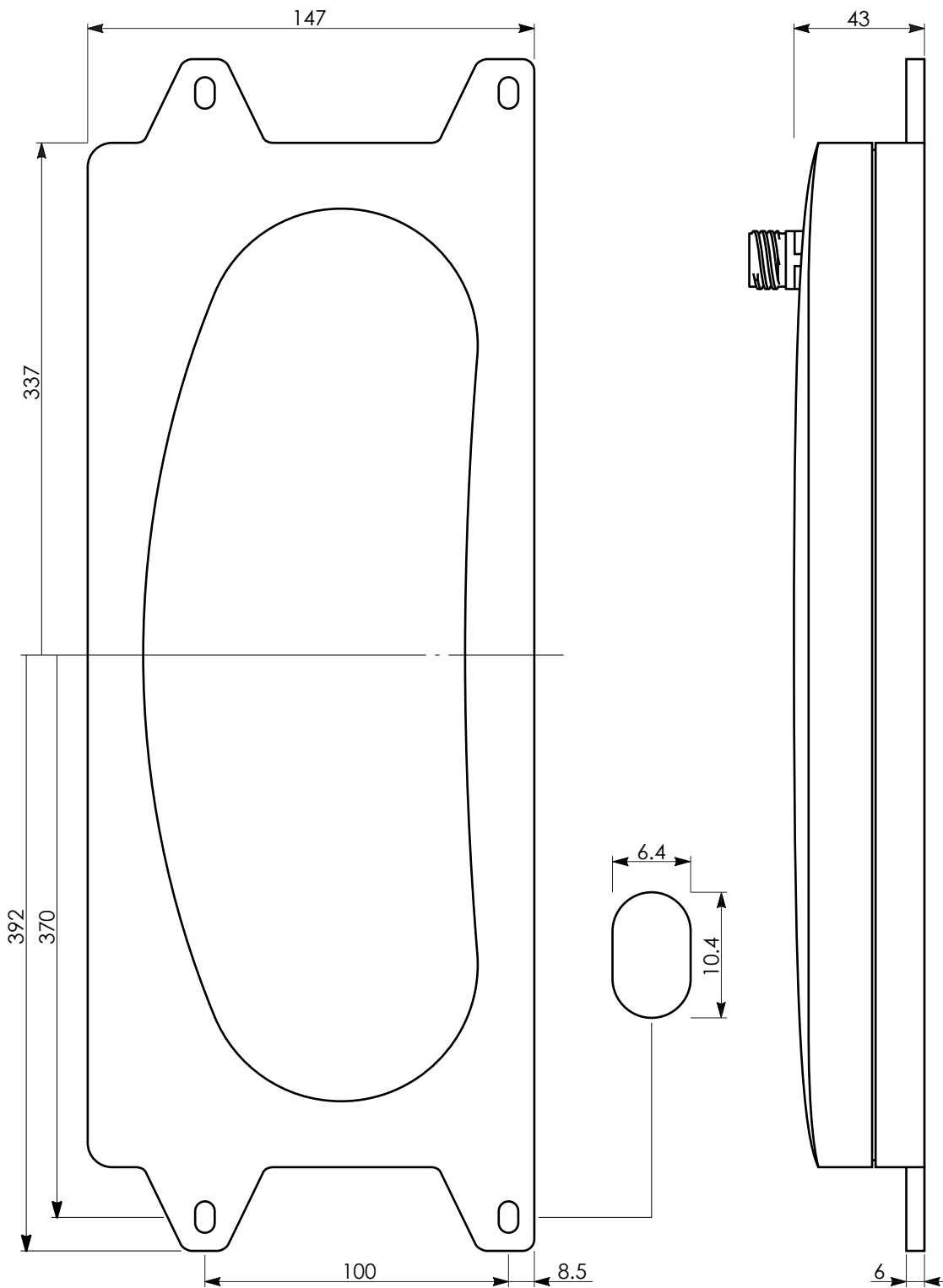
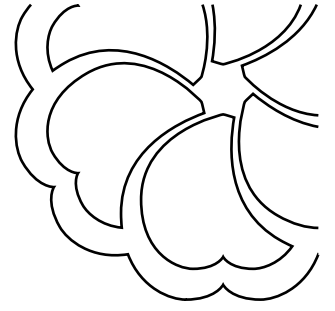
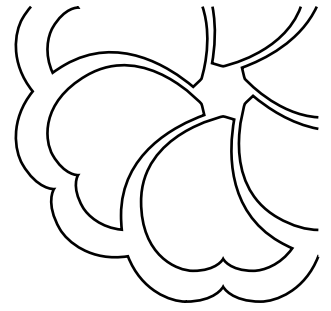

Fig. 3. VIC Laplace Z dimensions.

8

Options



Custom options for digital instrument cluster VIC Laplace Z:

custom graphical design

custom housing

custom programming

ambient light stereo sensing — used for automatic brightness adjusting

If your project requires options beyond listed here, write us to create a new device from scratch.

Our address

inquiry@librow.com